

CAD FILE:

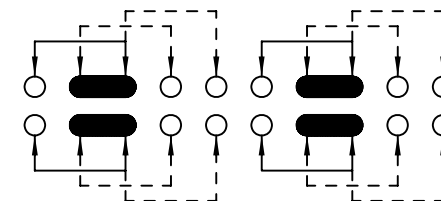

SCHEMATIC (SHORTING)

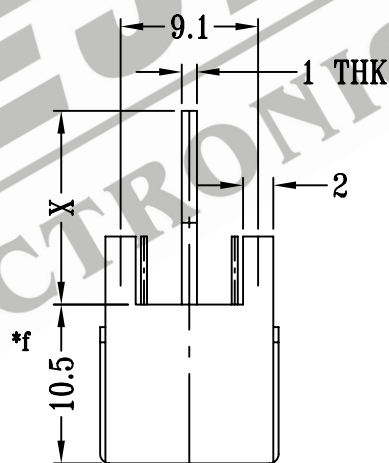
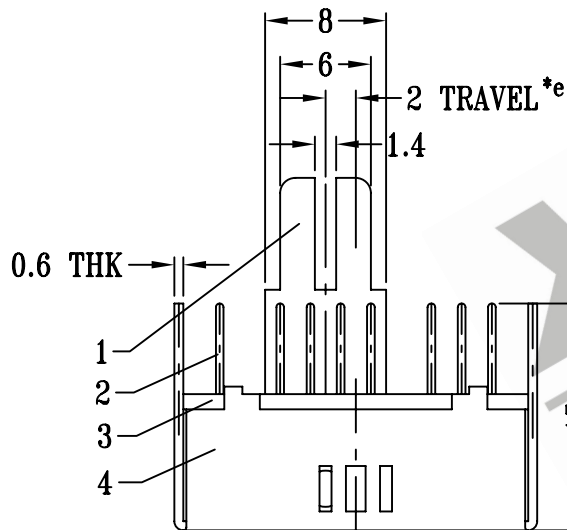
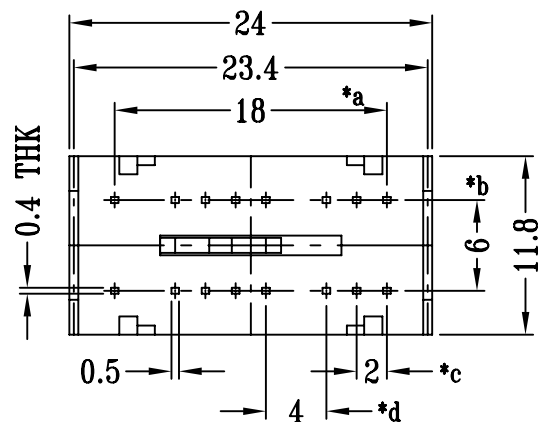
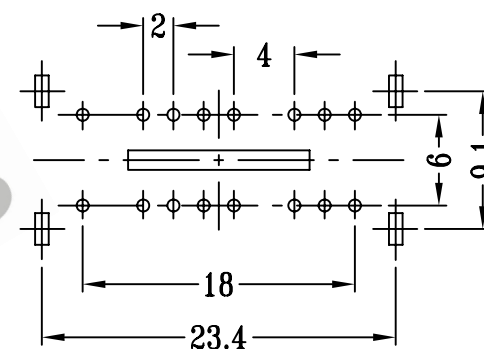

P.C.B LAYOUT

注:带"\*"表示关键尺寸(6个)

8	PRESS BAR	POM	1	BLACK	TOLERANCE UNLESS SPECIFIED	SHENZHEN XIEJIA ELECTRONICS CO.,LTD.				
7	STEEL BALL	STEEL	2	NATURAL						
6	SPRING	STEEL WIRE	1	TEMPER	WITHIN: 1.5±0.1mm	ISSUE	DATE	DESCRIPTIONS	APPD.	
5	CONTACT CLIP	PBS STRIP	4	Ag PLATED	OVER : 1.5±0.2mm					
4	FRAME	STEEL STRIP	1	Ni PLATED	TITLE : BOTTOM SLIDE SWITCH		UNIT : MM	DRWG NO.: XJ-DR-BK43D01-00		
3	BASE	PHENOLIC RESIN	1	NATURAL	MODEL: BK-43D01		SCALE: 2:1	DWN.	ZHOUYU	2001-9-15
2	TERMINAL	BRASS STRIP	16	Ag PLATED OVER Ni PLATED	ALL MATERIALS MUST BE COMPLIANT TO ROHS			CHK'D	FANGYING	2001-9-15
1	STEEL KNOB	STEEL STRIP	1	Ni PLATED				APPD.	KANGXINAN	2001-9-15
NO.	PART NAME	MATERIAL	Q'TY	FINISHING						